

KZch	Stück
EAC	
EAE	
EG	
ENO	1
EPB	
EPC	1
EPD	
ER	1
ERB	1
ERE	1
ERI	
ERK	
ERP	
ERS	
EWS	
FPS	
FPV	
FQS	
FWA	
FWB	
FWQ	
FWS	
FWT	
KE	2
KEL	2
KKR	1
RKA	
SAF	
SAP	1
SFD	
SFR1	
SFR2	
SFR3	
SFR4	
SFR5	
SP	
SQ	1
SWA1	
SWA2	
SWB	
SWE1	
SWE2	
SWW	
VEA	1
VEZ1	
VEZ4	
VEZ5	
VEZ7	
VEZ8	
VEZ10	
VEZ11	
VEZ13	
VEZ15	
VIH	1
VIP	1
VIT	
WMK	
WMW	

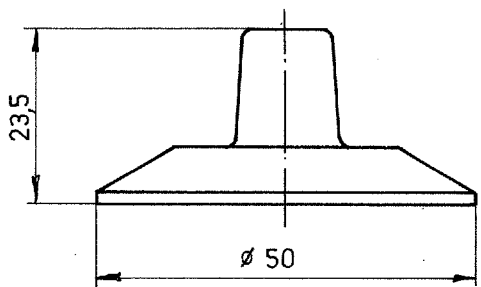

Maße der Knebelform  
siehe Zchnng. 0000 524.050

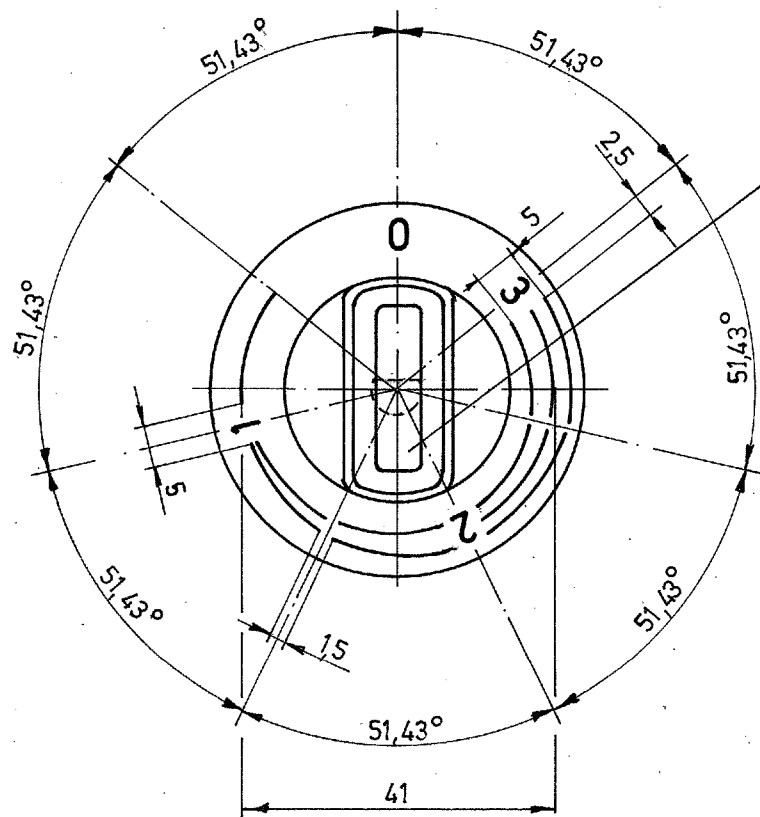

Knebelzierplättchen  
aluminiumfarben

Senkrechte Mittelschrift  
DIN17 Bl. 2 4mm hoch  
Strichdicke für Beschriftung  
und Schweiß 0,6mm

Farbe:  
Knebel: schwarz  
Beschriftung und  
Schweißkontur weiß

Stück	Benennung	Teil	Zeichnung-Nr.	Werkstoff	Fertigmaße/Bemerk.
VEA 1					Pausen-Nr.
VEZ1					
VEZ4					
VEZ5					
VEZ7					
VEZ8					
VEZ10					
VEZ11					
VEZ13					
VEZ15					
VIH 1					
VIP 1					
VIT					
WMK					
WMW					

Freimaßtoleranz	Oberfl./Beh.	Bestell-Nr.	
Gew. kp‰	<h1>Steckknebel</h1> <p>E-Regler 50.17 / 50.27 50.37 / 50.47</p>	<h1>0000 524.054</h1>	
brutto			Werkstoff
netto			Polyamid A
<b>E.G.O. ELEKTRO-GERÄTEBAU GMBH</b> D-7519 OBERDERDINGEN		1983 Tag Name Maßstab Bearb. 7.3. <i>A. Kroschke</i> 1:1 Gepr. 7.3. <i>SWW</i> Norm.	
		Ersatz für: Ersetzt durch:	